

Privacy Fencing - Top-of-Wall

1

Drill top of brick or block wall with 28mm core bit to a depth of 200 - 300mm to suit metal fixing stud.

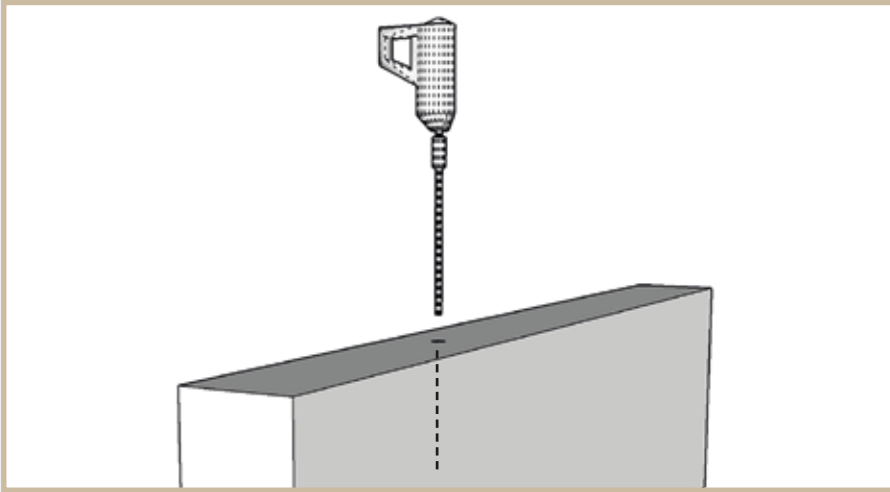

2

Apply two part resin chemical fixing into hole.

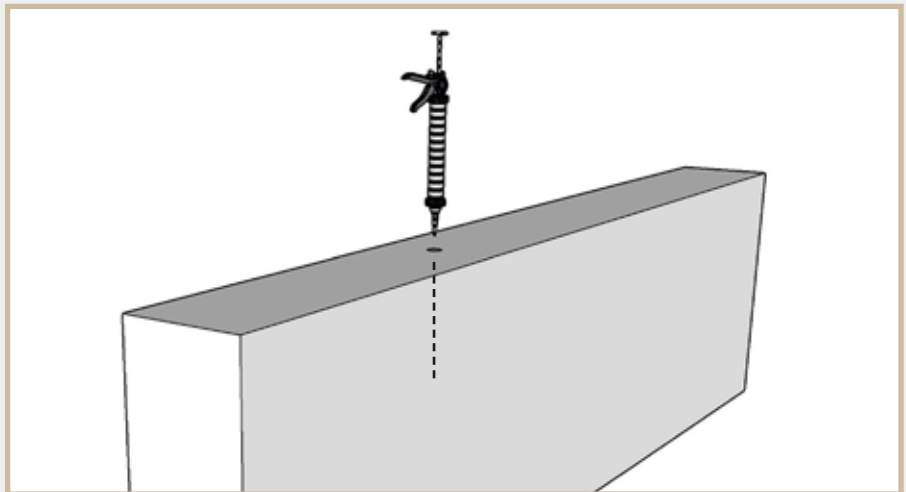

3

Fit Cequence top of wall post with metal fixing stud into hole.

Posts are available at:

300mm high
600mm high
900mm high
1200mm high

The metal stud can be cut to size to suite the depth of hole drilled.

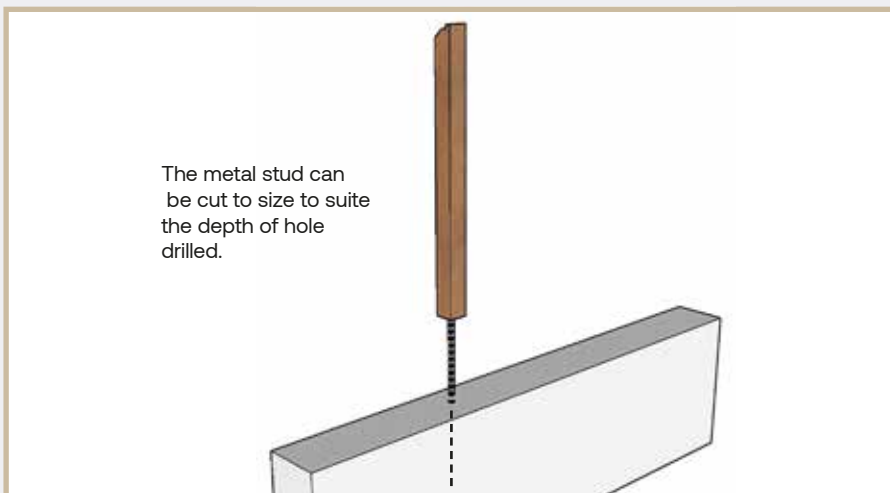

Privacy Fencing - Top-of-Wall

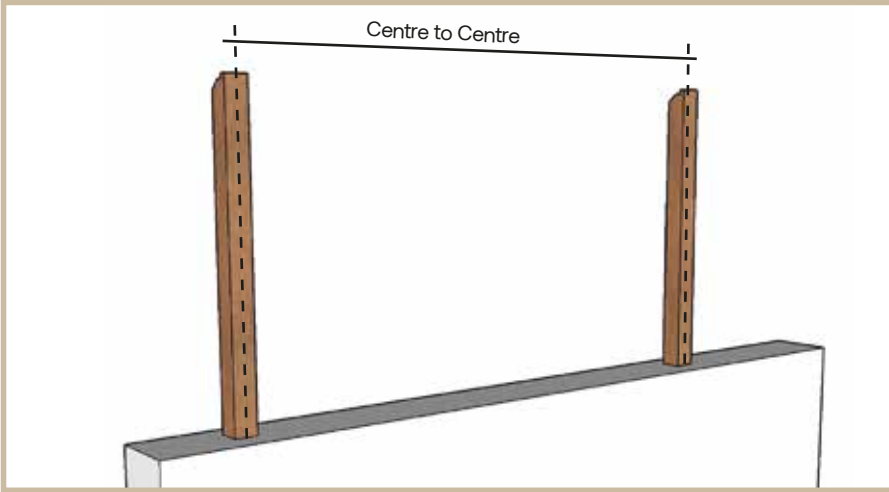

4

Position of post centres to be equal to the width of the fence panel to be installed.

When at the end of a fence run the panel should end on the outer edge of a post.

5

Screws should pass through the rebate between the horizontal boards into the back batten and then into the post.

63mm cedar coloured powder coated stainless steel screws should be used.



6

Intermediate panels are fixed midway to the front of the post. For end of a fence run the panel should be fixed on the outer edge of a post.

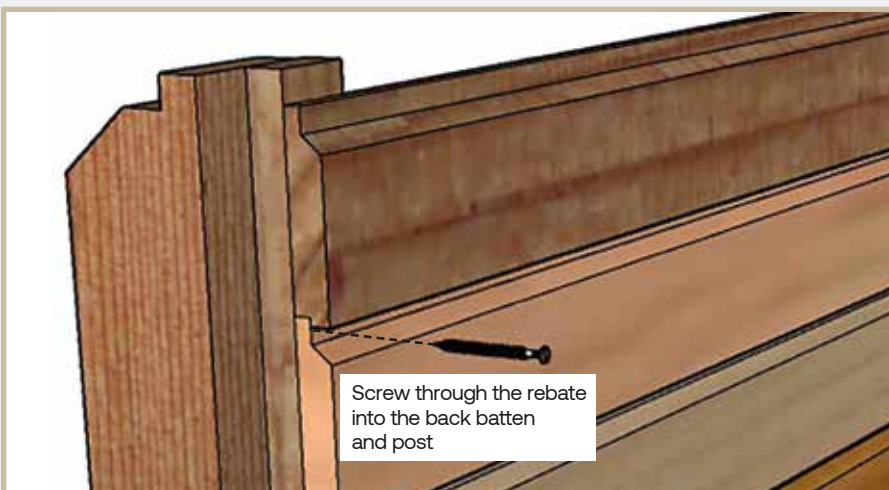

Privacy Fencing - Top-of-Wall

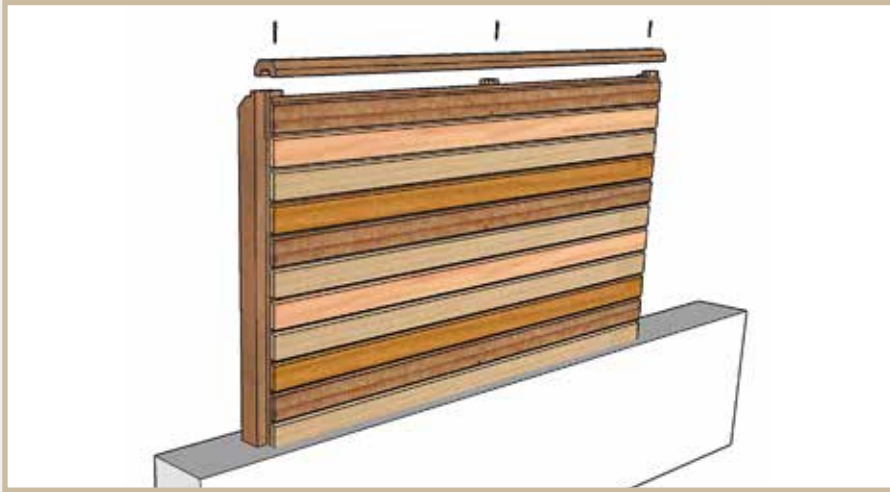

7

The Capping Rail is pushed down onto the profiled post top and back batten upstand.

3off 63mm cedar coloured powder coated stainless steel screws should be used to fix the capping rail into position.

8

The completed panel

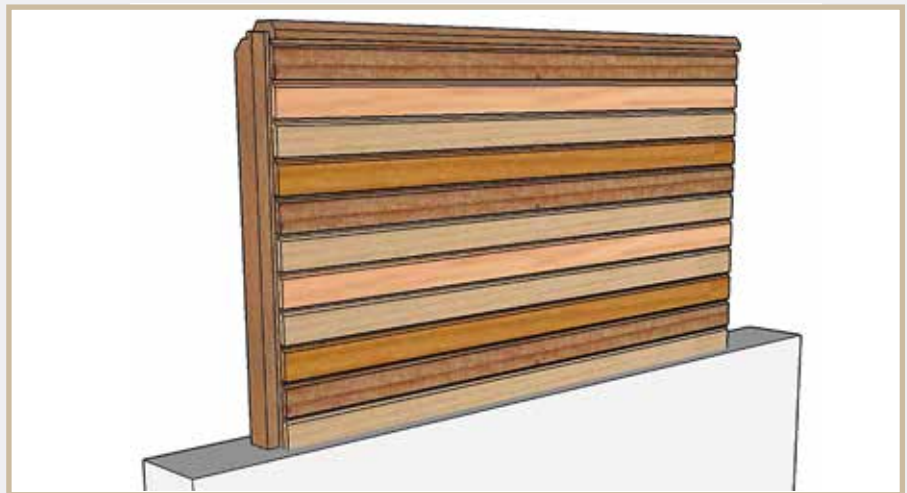

9

Rear view of fencing

