

**1**

Drill top of brick or block wall with 28mm core bit to a depth of 200 - 300mm to suit metal fixing stud.

**2**

Apply two part resin chemical fixing into hole.

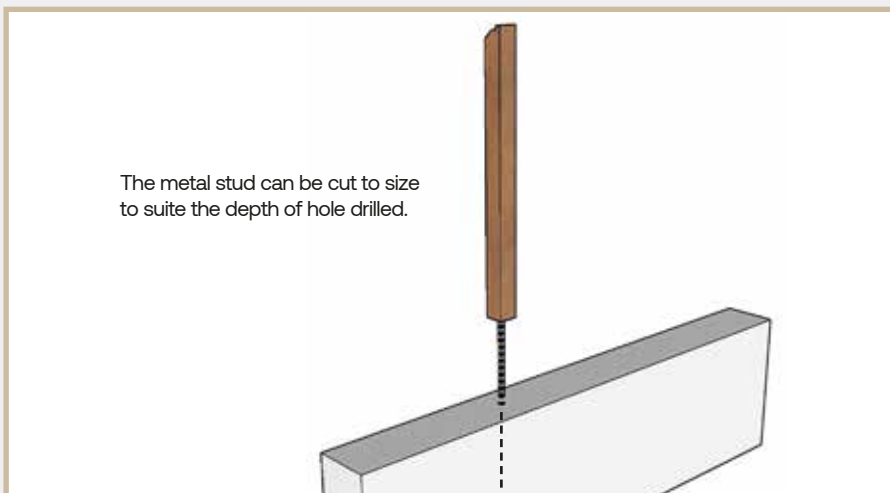
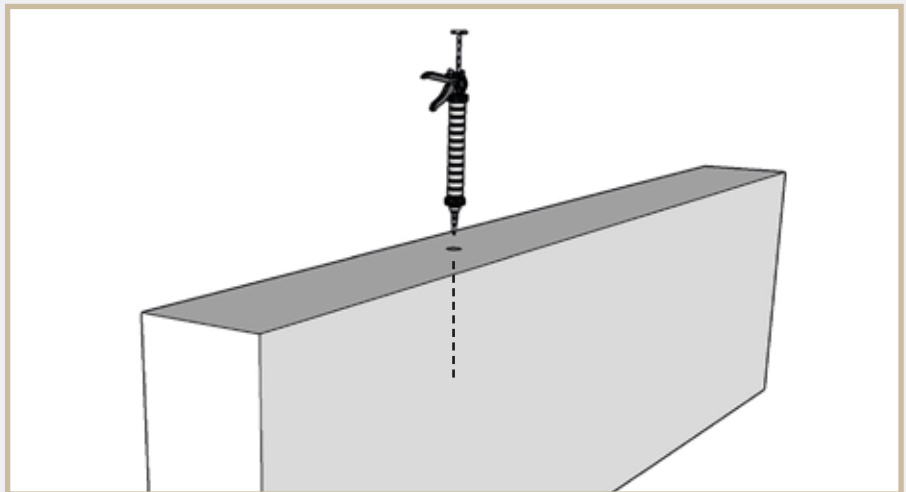

The metal stud can be cut to size to suite the depth of hole drilled.

**3**

Fit Cequence top of wall post with metal fixing stud into hole.

Posts are available at:-  
300mm high  
600mm high  
900mm high  
1200mm high

## Top of Wall Fencing

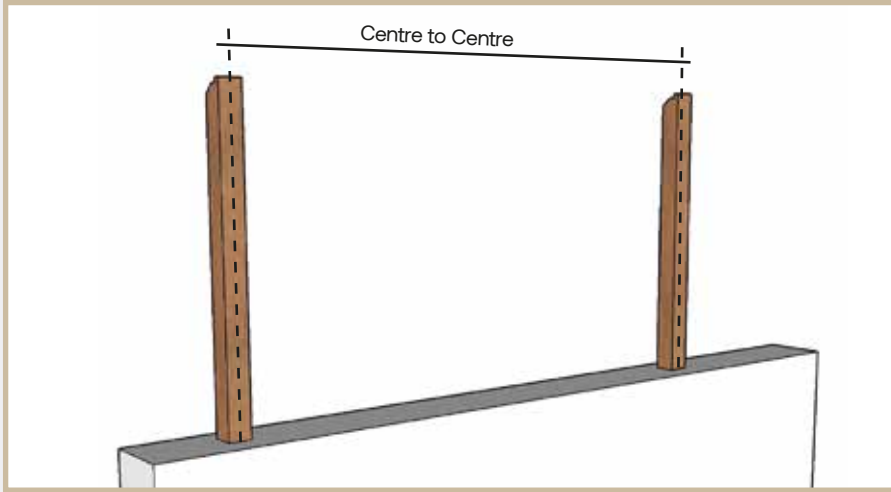

4

Position of post centres to be equal to the width of the fence panel to be installed.

When at the end of a fence run the panel should end on the outer edge of a post.

5

Screws should pass through the gaps between the horizontal battens into the front of the back batten and then into the post.

63mm cedar coloured powder coated stainless steel screws should be used.

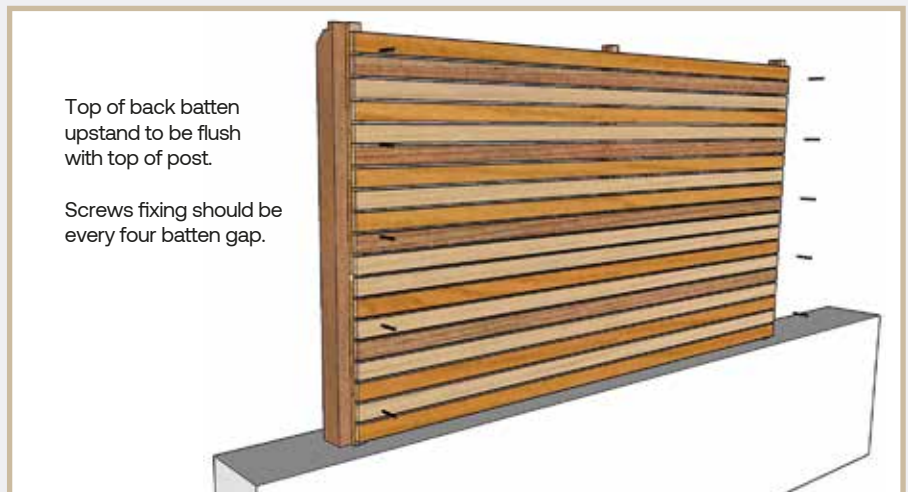

6

Intermediate panels are fixed midway to the front of the post. For end of a fence run the panel should be fixed on the outer edge of a post.

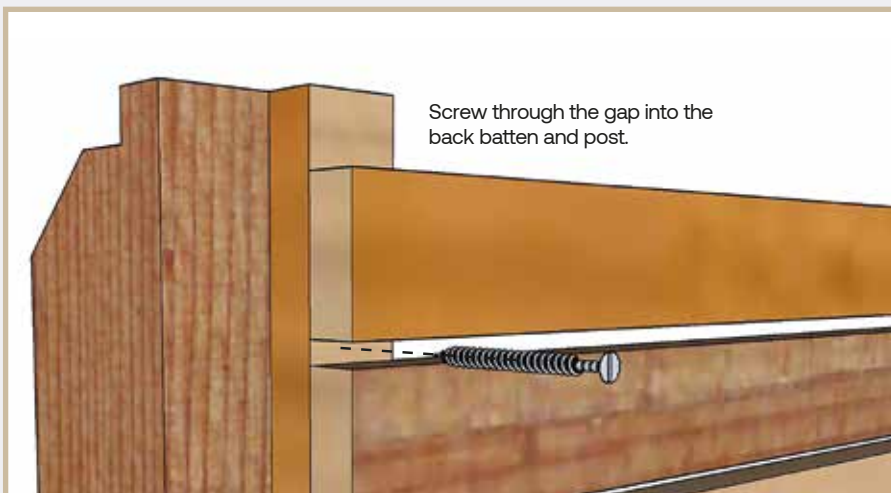

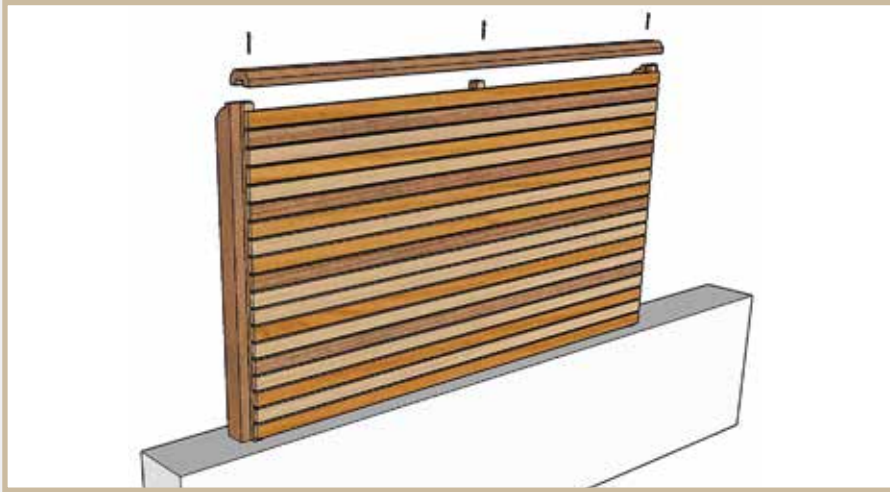

7

The Capping Rail is pushed down onto the profiled post top and back batten upstand.

3 off 63mm cedar coloured powder coated stainless steel screws should be used to fix the capping rail into position.

8

Attaching the Capping Rail.

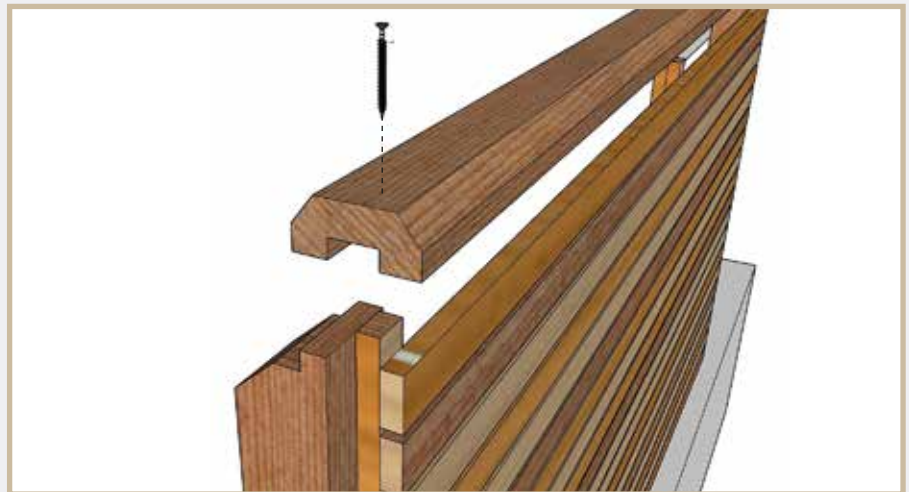

9

The completed panel.

